

DAVID YURMAN

SOHO | 114 PRINCE STREET, NEW YORK, NY 10012

STOREFRONT ENHANCEMENT

FLAG POLE AND BANNER INSTALLATION AND BLADE SIGN RELOCATION

CURRENT BUILDING PHOTOGRAPH



PLOT PLAN

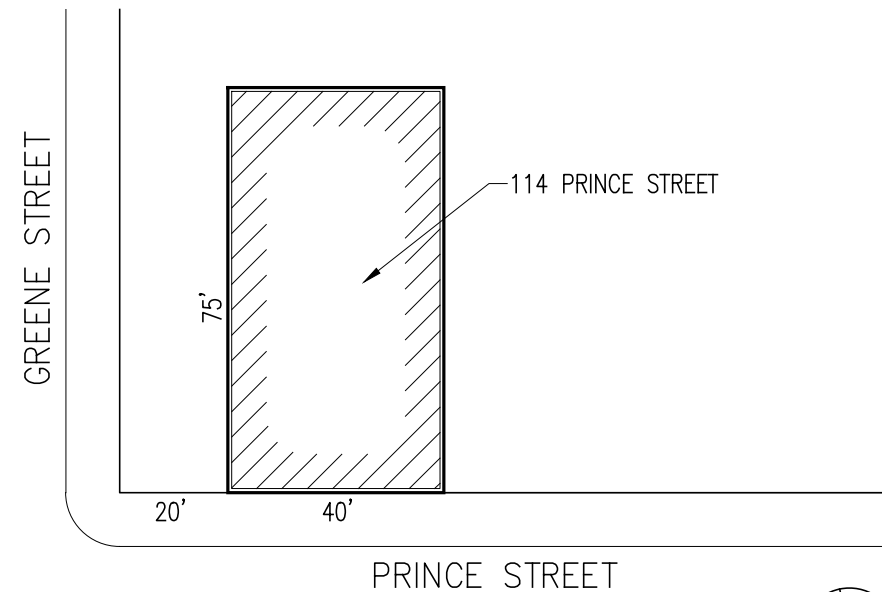

BLOCK: 500
LOT: 19
ZONE: M1-5A
MAP: 12C
OCCUPANCY CLASSIFICATION: MERCANTILE
CONSTRUCTION CLASS: CLASS 3
HEIGHT: 5 FLOORS (93'-2")

BUILDING OCCUPIES ENTIRE LOT
(5 STORIES) - NO SETBACKS

VICINITY MAP



AERIAL VIEW





1940 Tax Photo

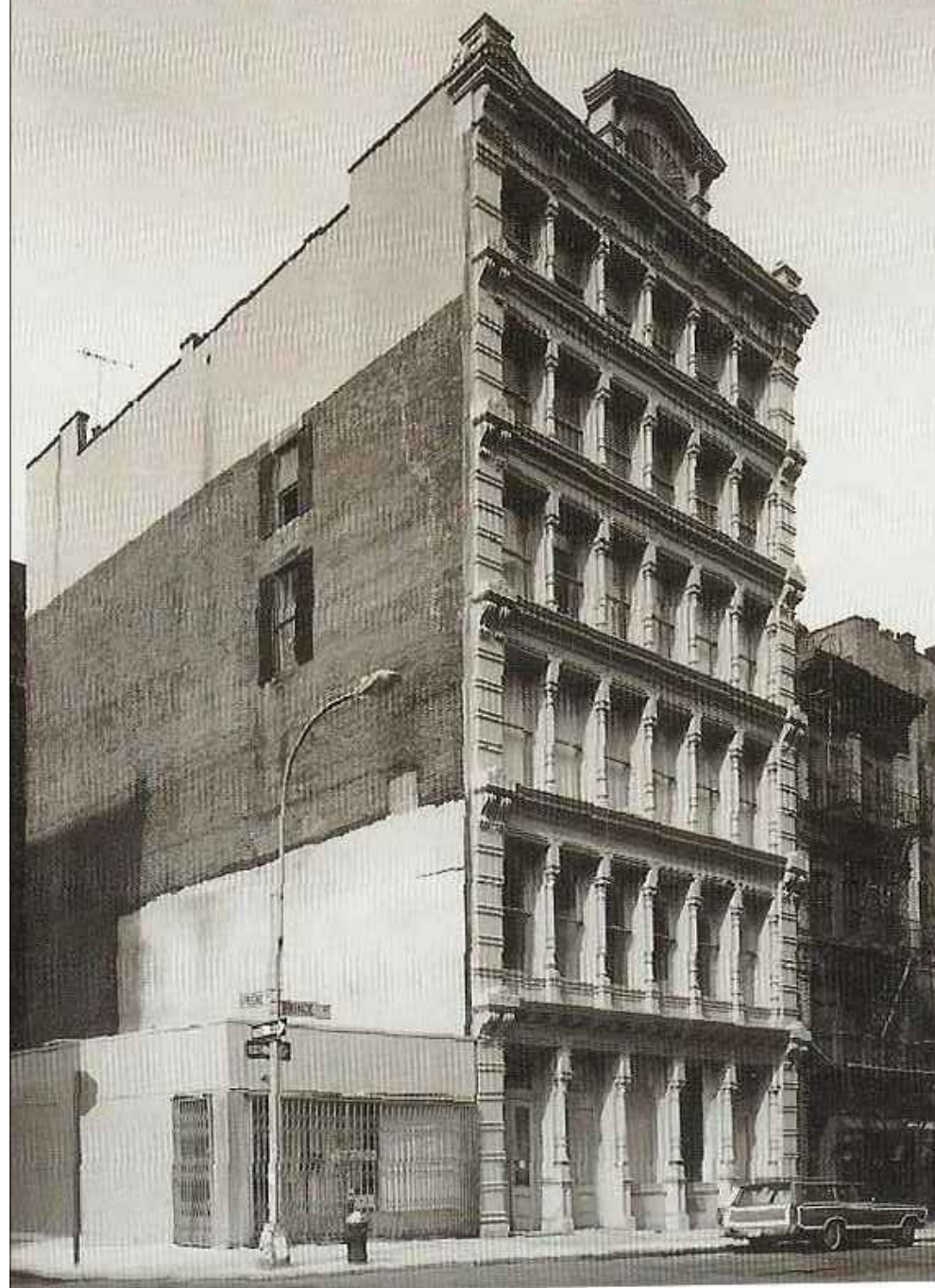

Pre-1975, Pre-mural



Circa 1975

PROPOSED LOCATION OF
NON-ILLUMINATED
FLAGPOLE AND BANNER

PROPOSED LOCATION
OF NON-ILLUMINATED
BRACKET SIGN

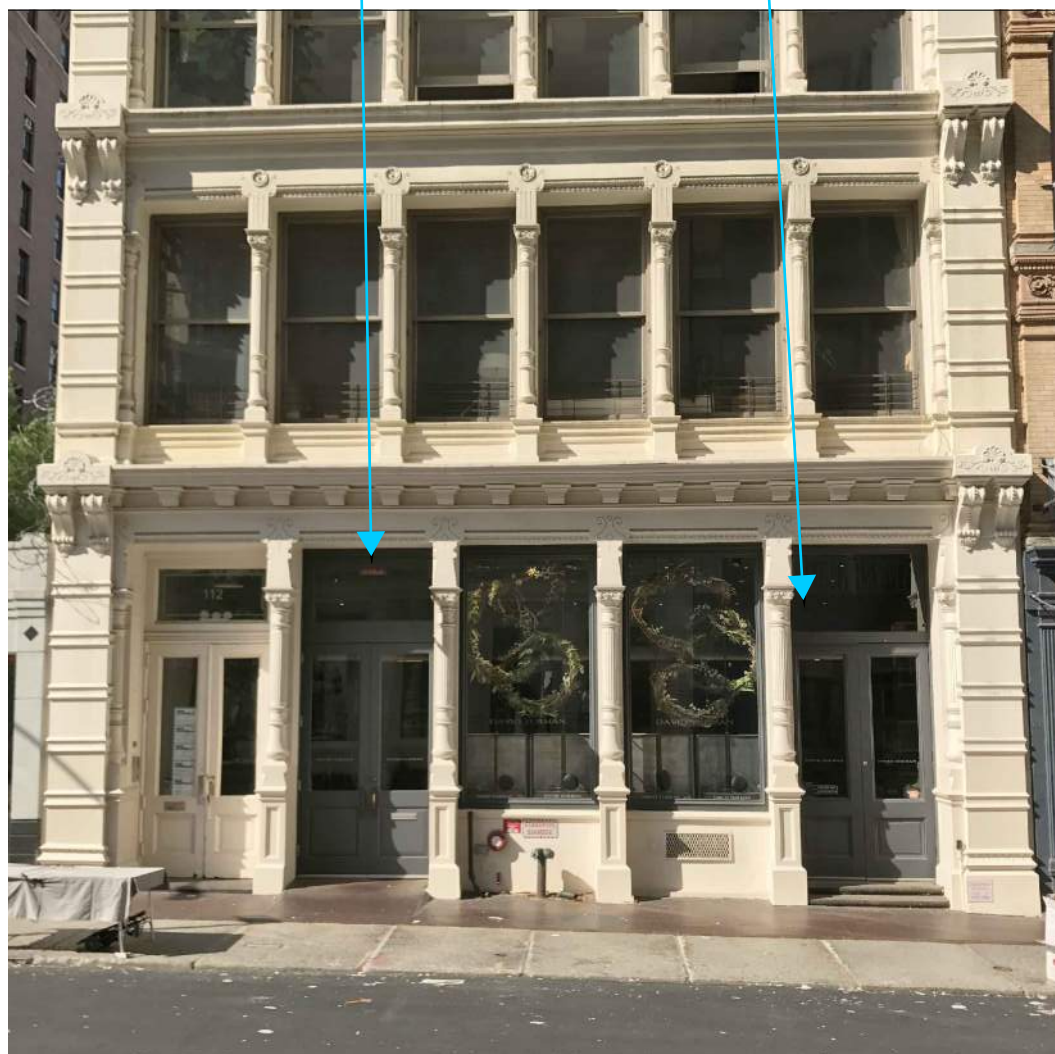

1 EXISTING STOREFRONT FACADE
SCALE: NTS

PROPOSED LOCATION OF
NON-ILLUMINATED BRACKET
SIGN ATTACHMENT

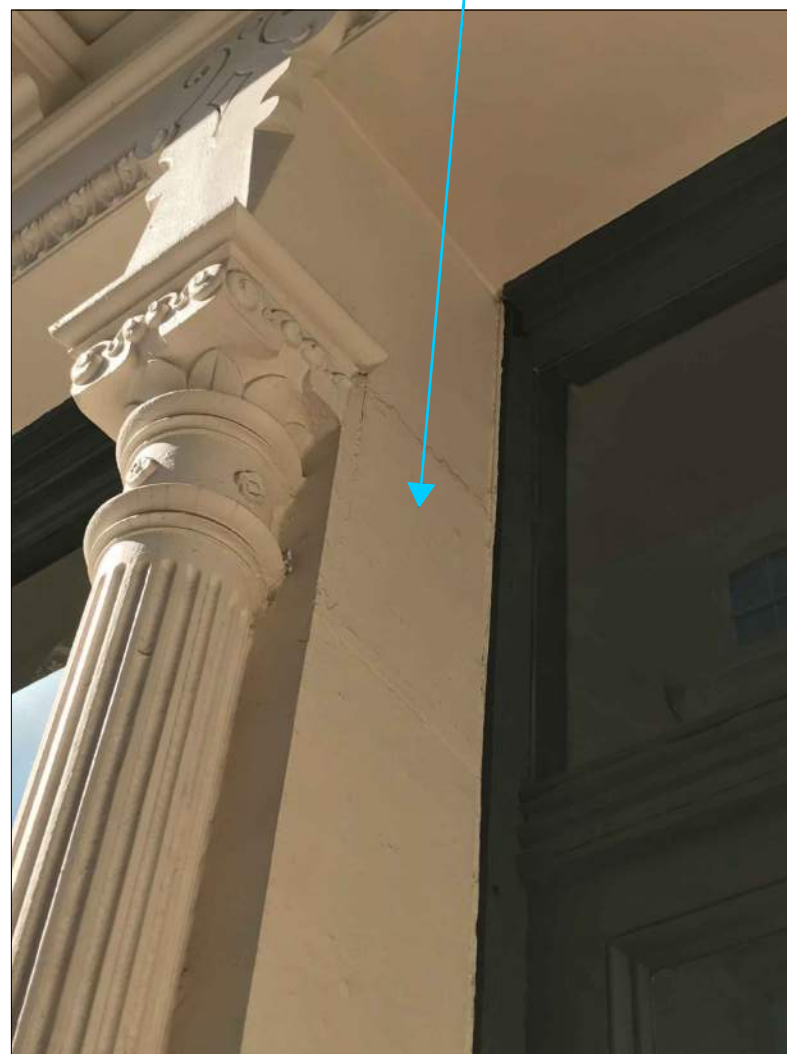

2 PROPOSED BRACKET SIGN LOCATION
SCALE: NTS

PROPOSED LOCATION OF
NON-ILLUMINATED FLAGPOLE
AND BANNER ATTACHMENT

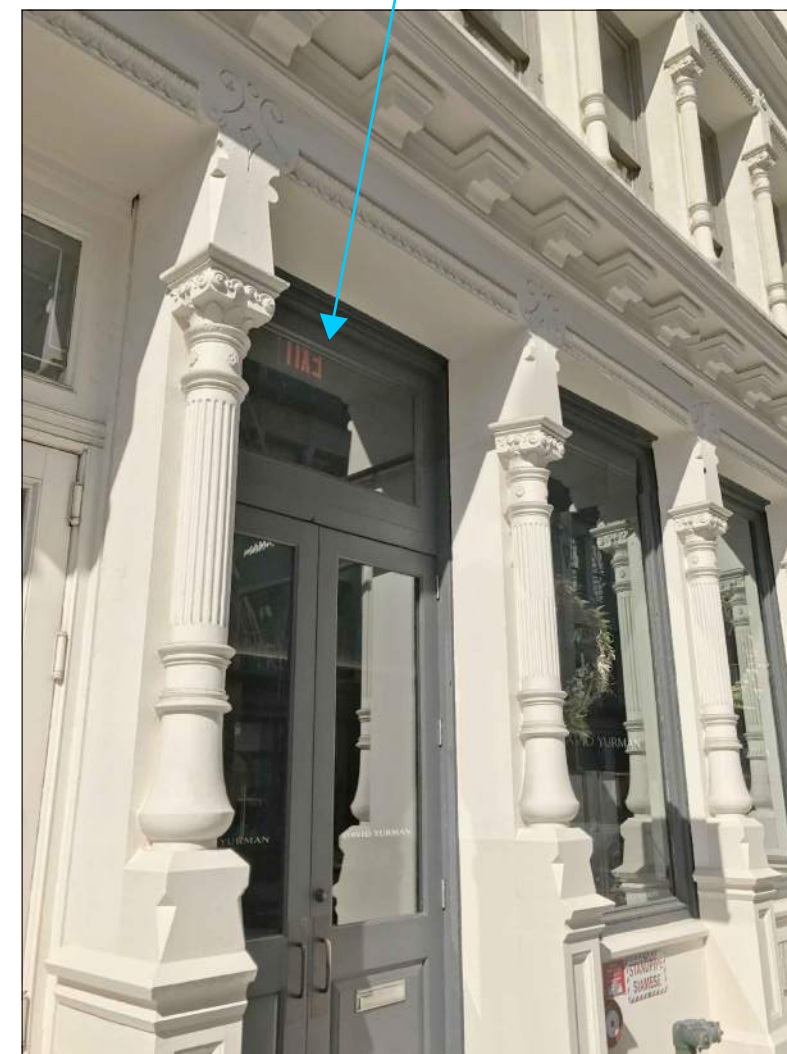

3 PROPOSED FLAGPOLE LOCATION
SCALE: NTS

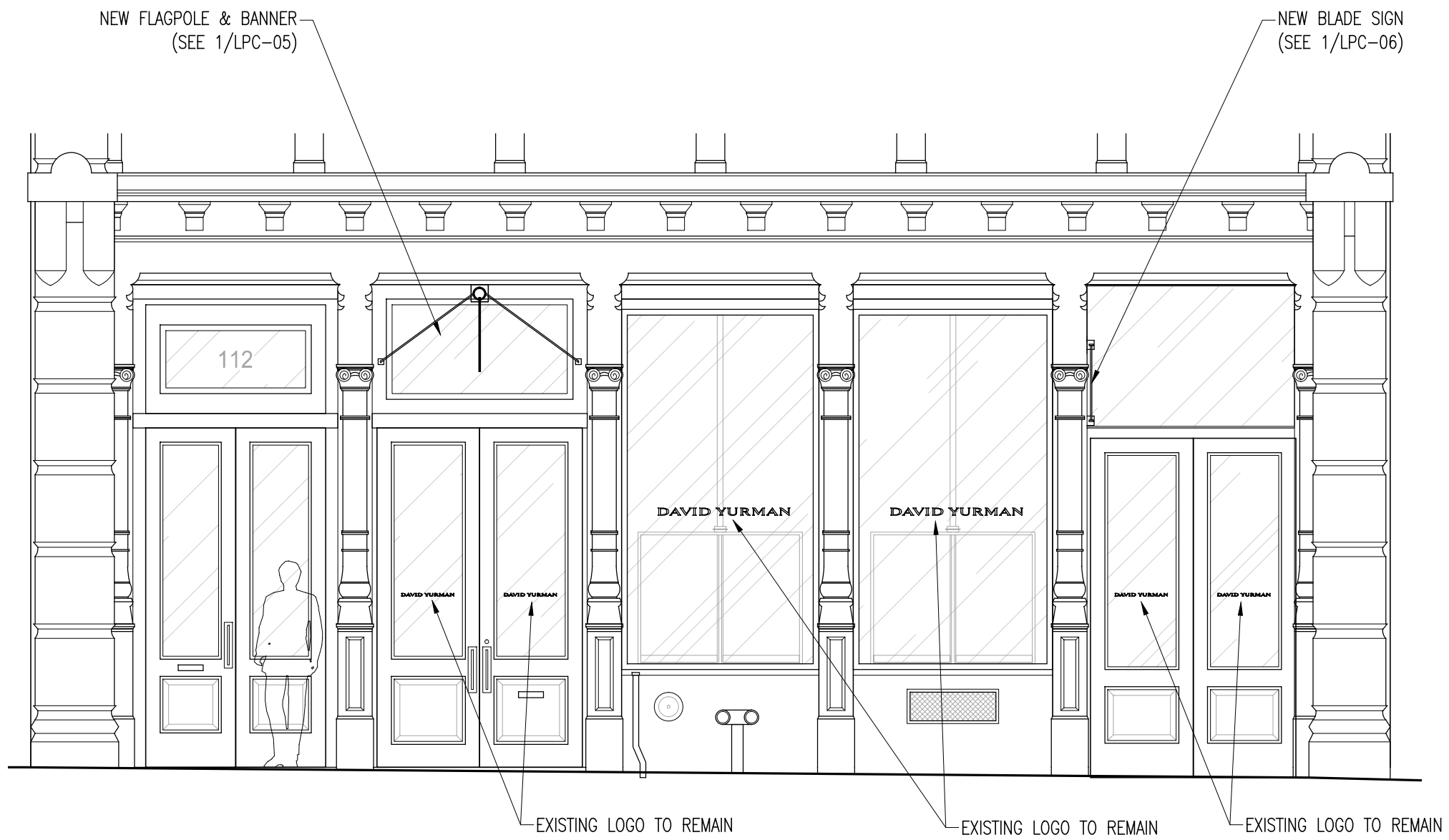

2 EXISTING STOREFRONT ELEVATION
SCALE: 1/4" = 1'-0"

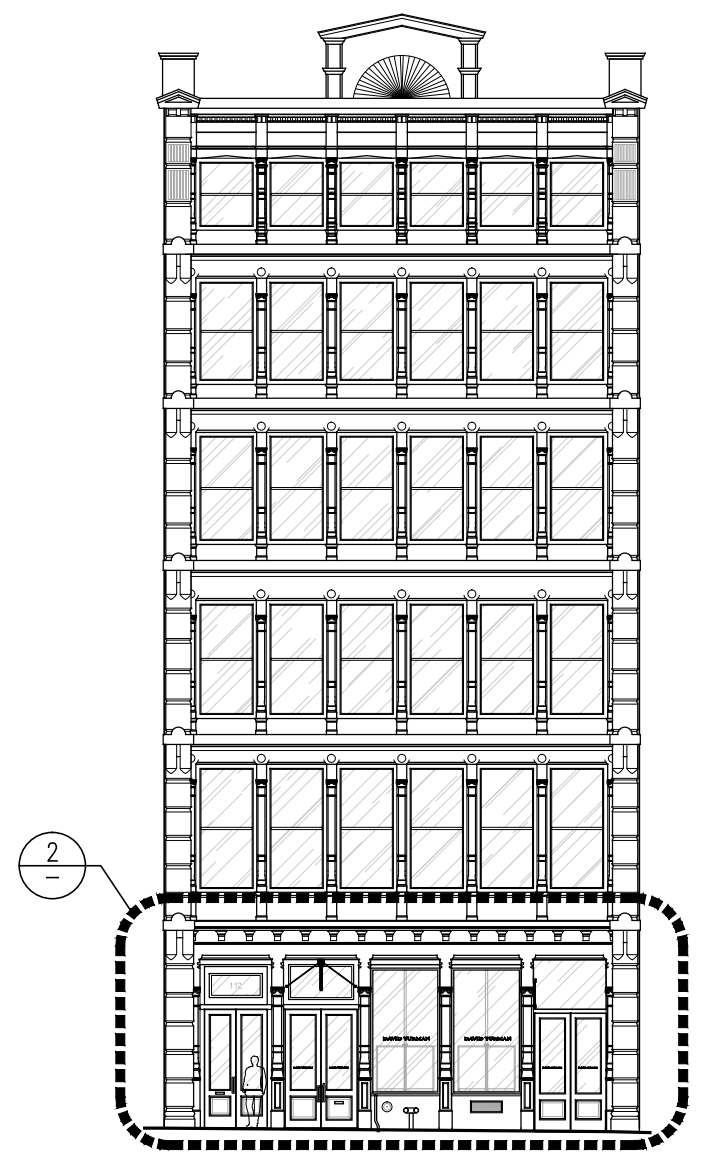

1 EXISTING FACADE ELEVATION
SCALE: 1/16" = 1'-0"



3 PHOTOMONTAGE OF PROPOSED FLAG LOCATION

SCALE: NTS

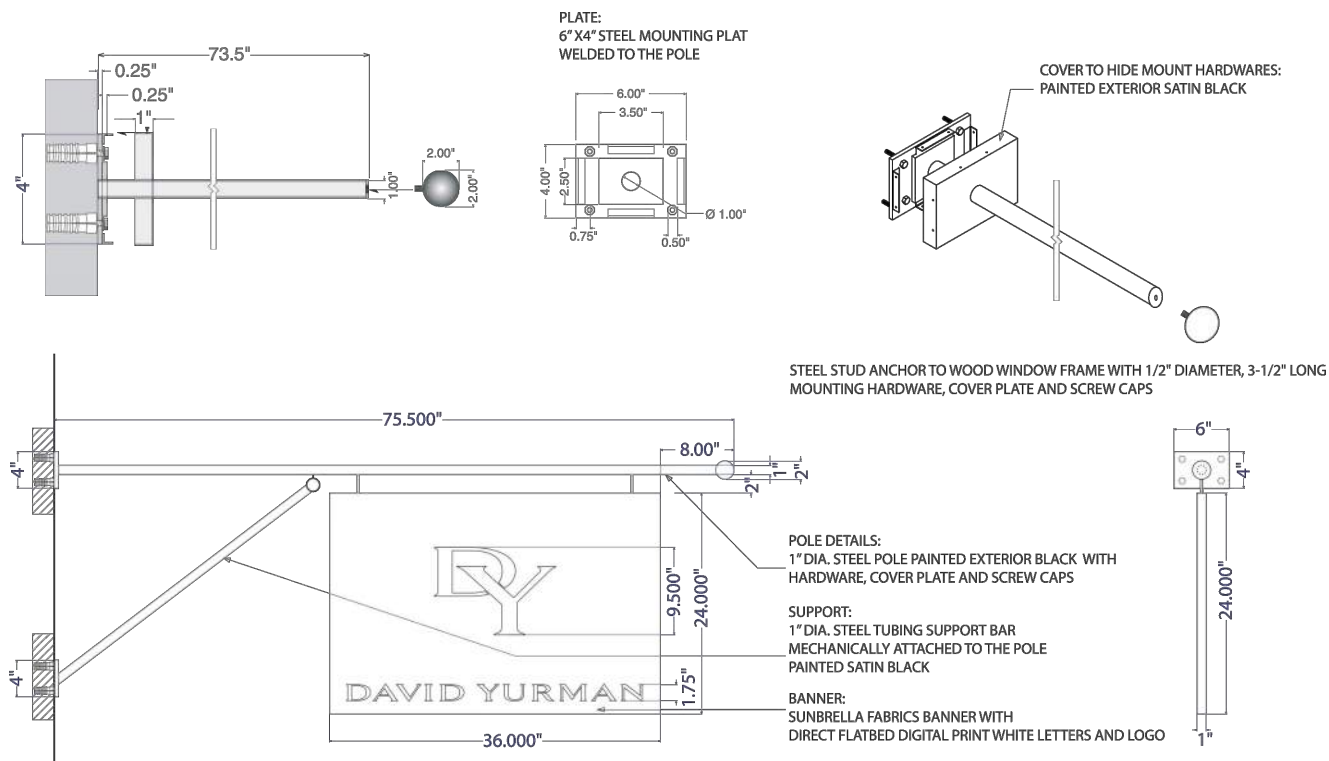

2 BANNER & FLAGPOLE DETAILS

SCALE: NTS

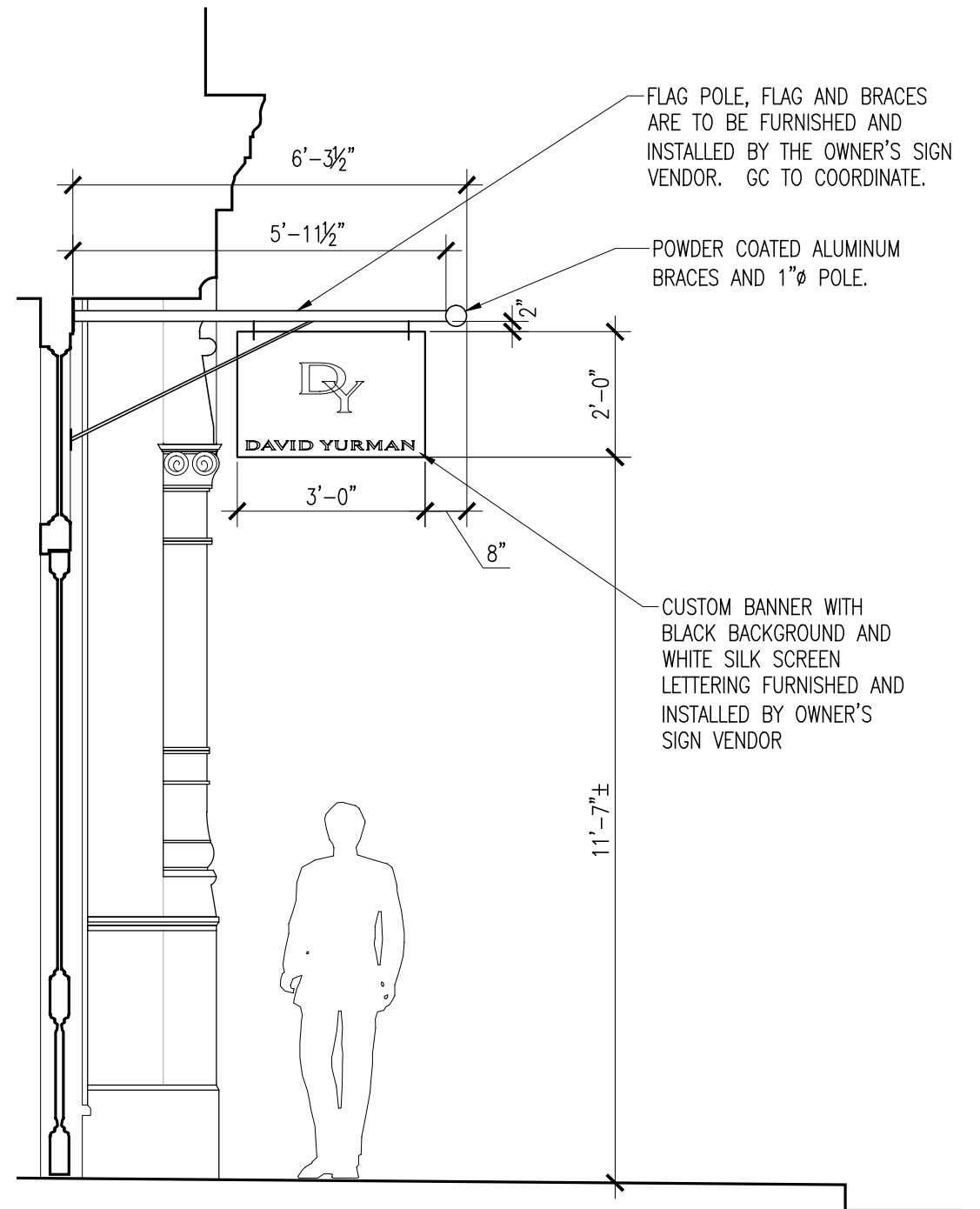

1 BANNER & FLAGPOLE - STOREFRONT ELEVATION

SCALE: 3/8"=1'-0"



3 PHOTOMONTAGE OF PROPOSED SIGN LOCATION
SCALE: NTS

DAVID YURMAN, 114 PRINCE STREET, BANNER POLE SIGN 2-28-17

REMOVE, FIX BRACKET AND REINSTALL
SIGN CONDITION REMAIN AS IS, NO WORK TO BE DONE ON SIGN,
SIGN WILL BE CLEAN UP, FIX AND WELDED NEW PLATE TO THE POLE
FOR INSTALL PROPOSED LOCATION

QUANTITY: 1

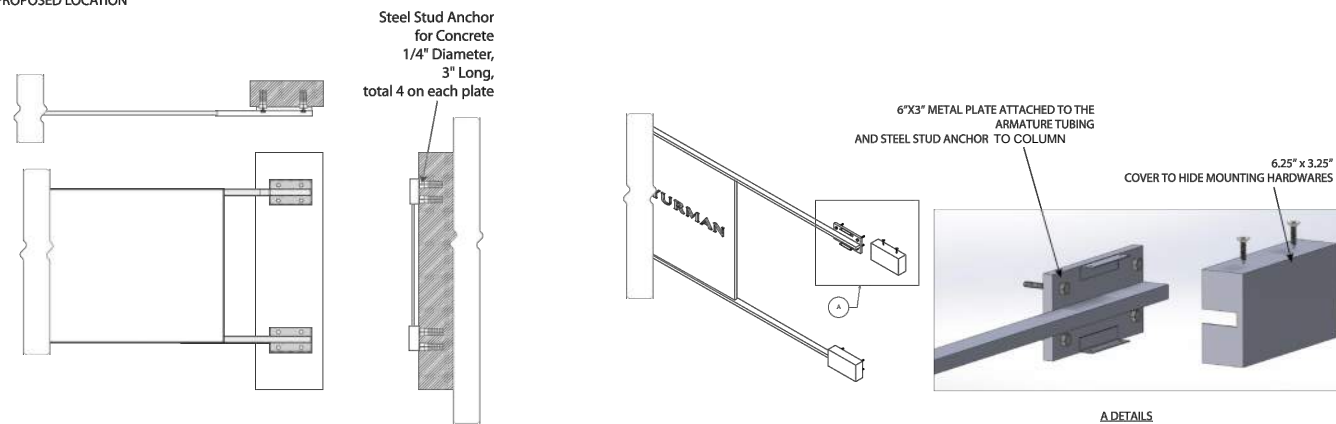

2 BRACKET SIGN DETAILS
SCALE: NTS

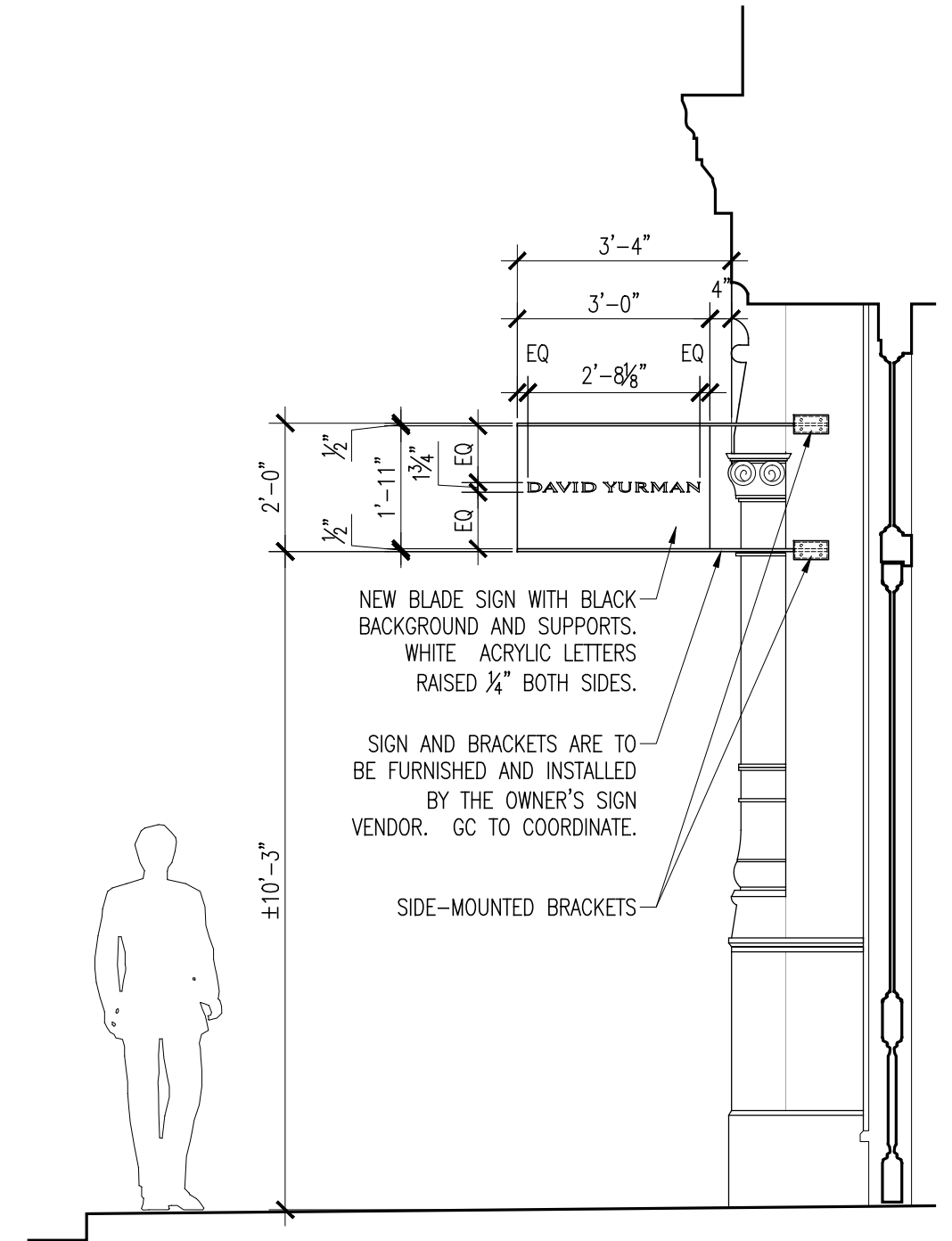

1 BLADE SIGN ELEVATION
SCALE: 3/8"=1'-0"

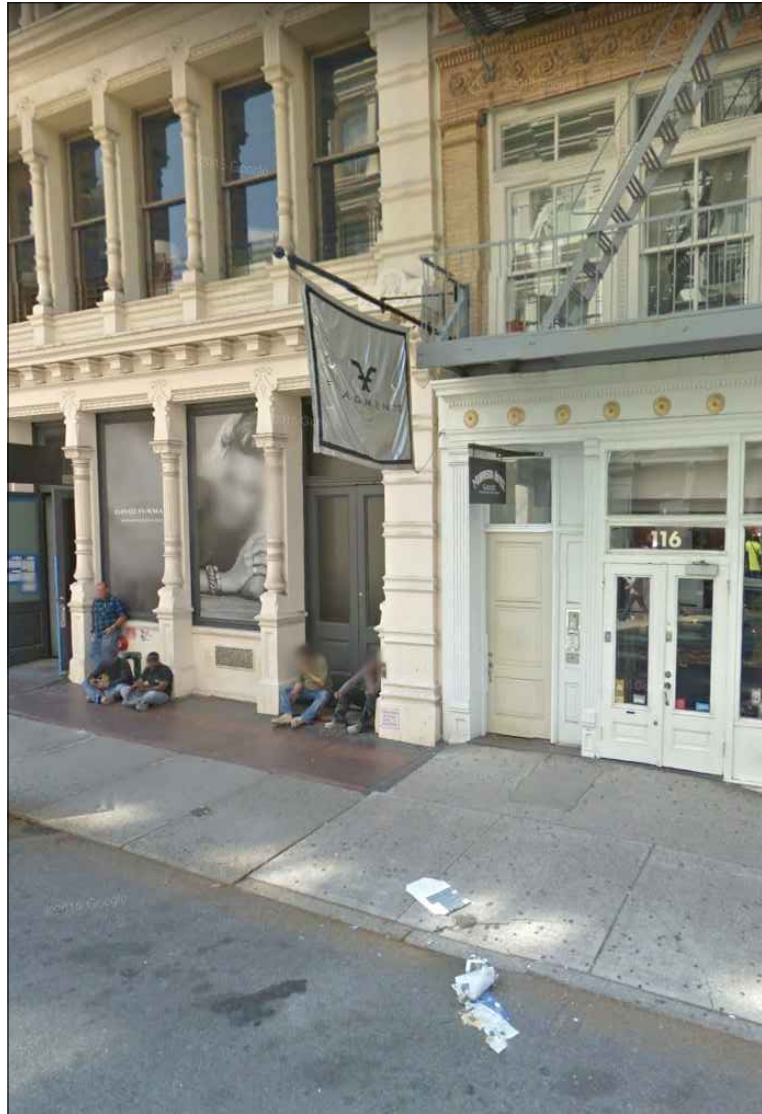

Morrison Hotel Gallery
116 Prince Street



Under Armour
583 Broadway



Levi's
495 Broadway

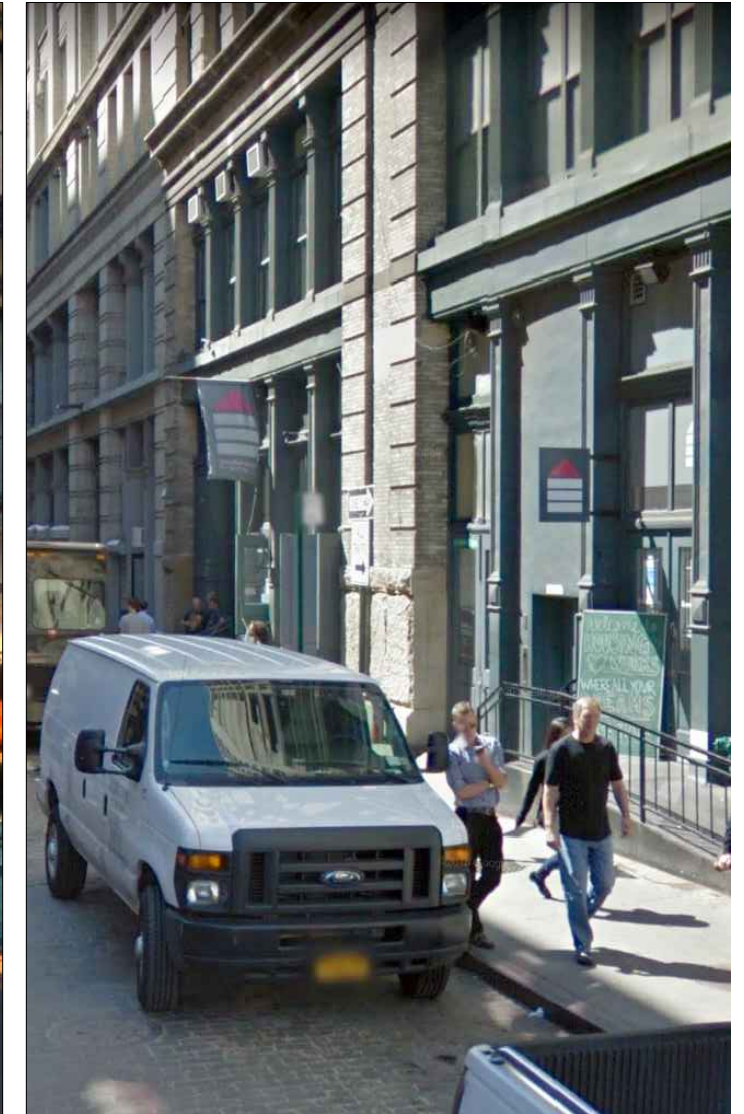

Housing Works Bookstore & Cafe
126 Crosby Street